

CAD FILE:

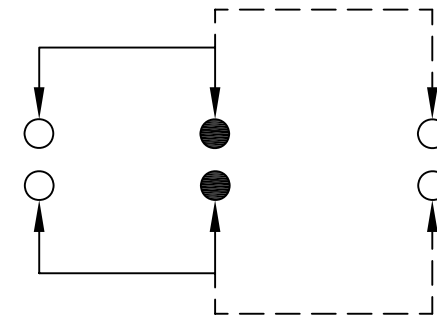

SCHEMATIC (NON-SHORTING)

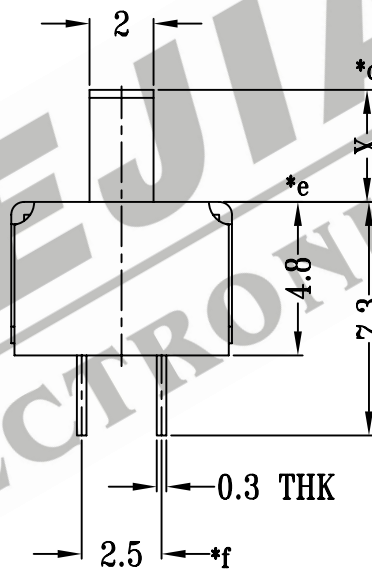
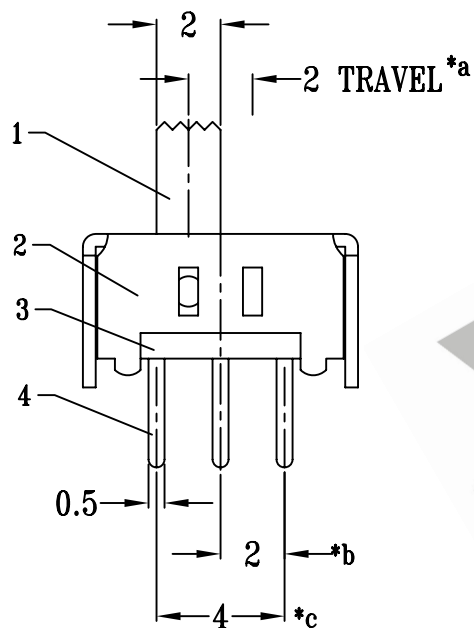
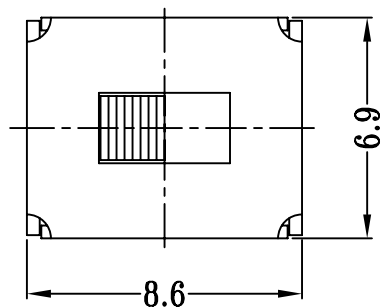
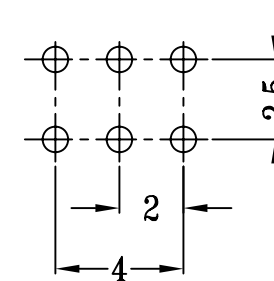

P.C.B LAYOUT

注:带*表示关键尺寸(6个)

				TOLERANCE UNLESS SPECIFIED	SHENZHEN XIEJIA ELECTRONICS CO.,LTD.				
				WITHIN: 1.5±0.1mm OVER : 1.5±0.2mm	ISSUE	DATE	DESCRIPTIONS OF REVISION		APPD.
8									
7									
6	SPRING PLATE	STAINLESS STEEL	2	NATURAL	TITLE : VERTICAL SLIDE SWITCH		UNIT : mm	DRWG NO.: XJ-DR-SS22D02-00	
5	CONTACT CLIP	PBS	2	Ag CLAD				DWN. ZHOUYU 2002-9-17	
4	TERMINAL	BRASS STRIP	6	Ag PLATED OVER Ni PLATED	MODEL: SS-22D02		SCALE: 4:1	CHK'D FANGYING 2002-9-17	
3	BASE	PHENOLIC RESIN	1	NATURAL				APPD. KANGXINAN 2002-9-17	
2	FRAME	STEEL STRIP	1	Ni PLATED	ALL MATERIALS MUST BE COMPLIANT TO ROHS				
1	KNOB	POM	1	BLACK					
NO.	PARTS	MATERIALS	Q'TY	FINISH					